

Shaft Couplings

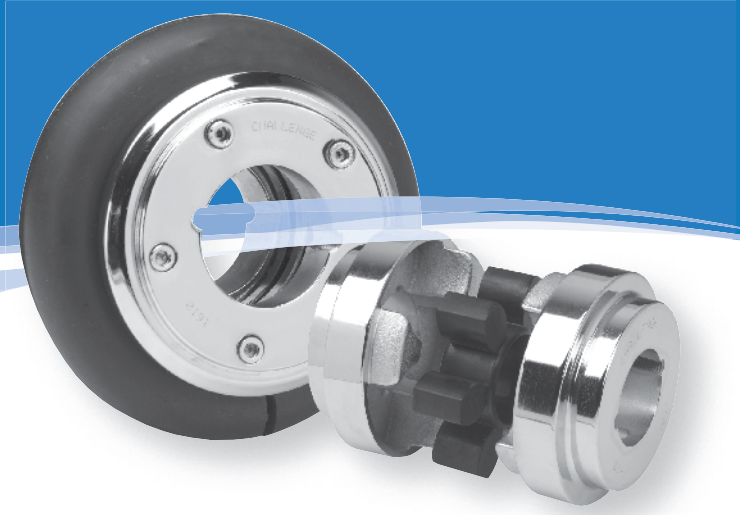

Features

FFX

- Up to 14675 Nm torque on 6 pole motors
- Up to 4° angular misalignment
- Up to 12° 'wind up' shock absorption
- Can accommodate simultaneous maximum misalignment in all planes
- Tyre can be changed without moving prime mover or driven machine
- Visual inspection of tyre to detect wear
- Zero backlash makes the FFX ideal for reversing duties as the load carrying cords are wound in both directions. Reversing drives are not a problem
- Steel clamping rings used throughout the range for superior tyre/clamping ring grip
- Fire resistant and anti static (FRAS) tyres available
- No lubrication required
- Taper bush and pilot bore flanges available

HRC

- Designed specifically for use with IEC motors
- Torques up to 3150 Nm
- Up to 1° angular misalignment
- Good shock absorption properties
- Quick and easy assembly
- Taper bush and Pilot bore flanges available
- High grade cast iron hubs
- Fail safe operation

NPX

- Designed to industry standard
- Available with three part flanges, thus allowing the segments to be changed without disturbing either the driving or driven shaft
- High levels of torsional flexibility
- High speed capability
- Suit IEC electric motor applications
- Taper bore and pilot bore flanges

RPX

- Fully machined with curved jaw design. This reduces vibration and allows for increased shock loading
- Designed to industry standard
- High torque for size
- Taper bore and pilot bore flanges
- 92 shore (yellow) and 98 shore (red) elements available

JAW

- International design
- Low cost wide range of sizes from 16 mm to 127 mm diameter

CHAIN

- High torque capacity
- Bores from 12 mm to 150 mm diameter
- Fully sealed casing with 'O' rings

FFX Tyre Coupling Selection

Tyre Coupling selection procedure

- 1] **Service Factor.**
From Table 1 on page 247, select the service factor that is appropriate for the application
- 2] **Design Power.**
Multiply the absorbed power of the driven machine, in kW, by the service factor, from step 1) to obtain the design power. If the absorbed power is not known, use the prime mover power.
- 3] **Tyre coupling size selection.**
Refer to Table 2 on page 247.
Read down the left hand vertical column to the required speed
Read horizontally across on the speed line until a power equal to or in excess of the design power, from step 2), is reached.
Read vertically to the top of the column to obtain the correct size of tyre coupling.
- 4] **Bore dimensions.**
From the dimensions Table on page 248, check that the selected coupling will fit the shafts.

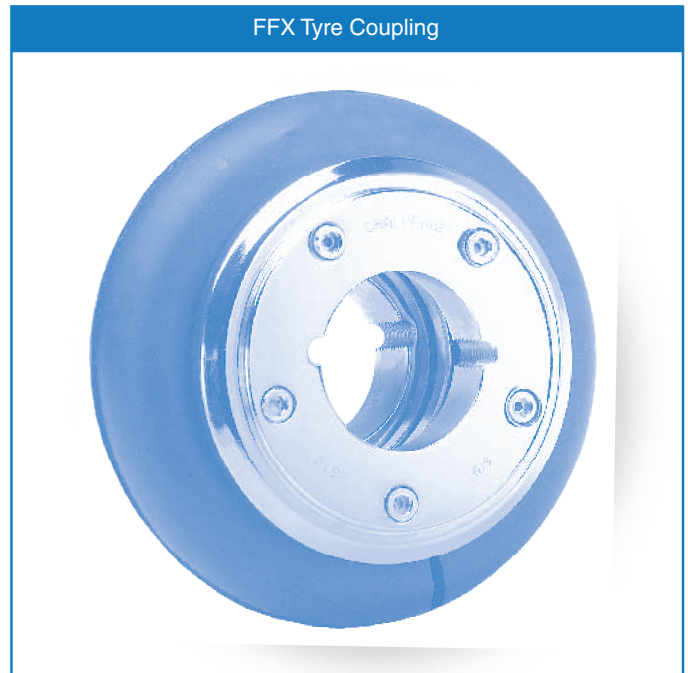

Tyre Coupling selection example

Select a Challenge tyre coupling to drive a reciprocating pump from a 980 rev/min, 30 kW electric motor. The pump absorbs 24 kW and runs for 16 hours/day. The motor shaft is 60 mm diameter and the pump shaft 55 mm diameter. Taper bush flanges are required for both shafts.

- 1] **Service factor.**
From Table 2 on page 247, the service factor for this application is 1.9
- 2] **Design power.**
Using the absorbed power of the pump, the design power is $24 \times 1.9 = 45.6$ kW
- 3] **Tyre coupling size selection.**
Refer to Table 2 on page 247
By reading down and interpolating for the required speed of 980 rev/min, it is seen that an FFX 090 will transmit 50.45 kW which is in excess of the 45.6 kW required from step 2)
- 4] **Bore dimensions.**
From the dimensions Table on page 248, it is seen that both 'F' and 'H' flanges on an FFX 090 take a 2517 taper bush which are available with bores to suit the shaft requirements of the application.

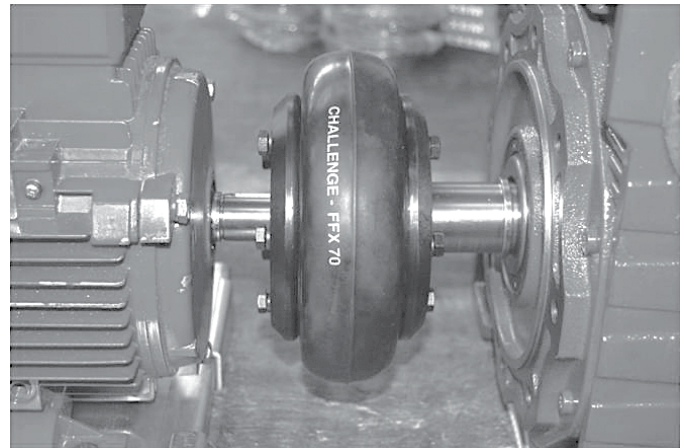

FFX Tyre Coupling Selection

Table 1, Service Factors

Special cases For applications where shock, vibration and torque fluctuations occur – consult Challenge	Type of prime mover					
	'Soft' Starts			'Heavy' Starts		
	Electric motors and other smooth running prime movers			Internal Combustion Engines		
	Number of hours per day running					
Type of driven machine	10 and under	over 10 - 16 incl	over 16	10 and under	over 10 - 16 incl	over 16
Uniform load Light duty agitators, belt conveyors for sand etc., fans upto 7.5 kW, centrifugal compressors and pumps,	0.8	0.9	1.0	1.3	1.4	1.5
Moderate load Variable density agitators, belt conveyors (non-uniform loads), fans over 7.5 kW, other rotary compressors and pumps, generators, machine tools, printing machinery, laundry machinery, rotary screens, rotary woodworking machinery	1.3	1.4	1.5	1.8	1.9	2.0
Heavy load Reciprocating compressors and pumps, positive displacement blowers, heavy duty conveyors such as screw, bucket etc., hammer mills, pulverisers, presses, shears, punches, rubber machinery	1.8	1.9	2.0	2.3	2.4	2.5
Severe load Crushers – gyratory, jaw, roll etc., rolling mills, calenders, quarry machinery, vibrating screens	2.3	2.4	2.5	2.8	2.9	3.0

Table 2, Power Ratings (kW)

Rotational speed in rev/min	FFX 40	FFX 50	FFX 60	FFX 70	FFX 80	FFX 90	FFX 100	FFX 110	FFX 120	FFX 140	FFX 160	FFX 180	FFX 200	FFX 220	FFX 250
100	0.28	0.87	1.58	2.59	4.06	5.16	6.83	9.09	14.2	26.7	41.8	65.4	96.8	120	154
500	1.41	4.36	7.88	12.9	20.2	25.7	34.1	45.4	71.4	134	209	327	484	601	767
700	1.97	6.10	11.0	18.1	28.4	36.0	47.7	63.6	99.8	187	292	458	678	842	1074
720	2.02	6.26	11.3	18.6	29.2	37.1	49.1	65.4	103	192	301	471	697	866	1104
800	2.25	6.97	12.5	20.7	32.4	41.2	54.5	72.3	114	214	334	523	775	962	1227
900	2.53	7.84	14.1	23.3	36.5	46.3	61.4	81.8	128	241	376	589	872	1082	1380
960	2.69	8.36	15.1	24.8	38.9	49.4	65.5	87.3	137	257	401	628	929	1154	1472
1000	2.81	8.71	15.7	25.9	40.6	51.5	68.2	90.9	143	267	419	655	968	1203	1534
1200	3.37	10.4	18.9	31.0	48.6	61.8	81.8	109	171	321	502	785	1162	-	-
1400	3.93	12.2	22.0	36.2	56.8	72.1	95.5	127	200	375	585	916	-	-	-
1440	4.04	12.5	22.6	37.2	58.4	74.2	98.3	131	206	385	602	942	-	-	-
1500	4.21	13.0	23.6	38.8	60.9	77.3	102	136	214	401	627	982	-	-	-
1800	5.05	15.6	28.3	46.5	73.0	92.7	123	164	257	481	-	-	-	-	-
2000	5.62	17.4	31.5	51.8	81.1	103	136	182	286	-	-	-	-	-	-
2500	7.02	21.7	39.3	64.7	102	129	145	-	-	-	-	-	-	-	-
2880	8.08	25.0	45.3	74.5	117	149	-	-	-	-	-	-	-	-	-
3000	8.42	26.1	47.2	77.6	122	155	-	-	-	-	-	-	-	-	-
3500	9.82	30.4	55.1	90.6	-	-	-	-	-	-	-	-	-	-	-
4000	11.2	34.8	63.0	-	-	-	-	-	-	-	-	-	-	-	-
4500	12.6	39.1	-	-	-	-	-	-	-	-	-	-	-	-	-

All power ratings are constant torque
Interpolate for speeds not listed

Every effort has been taken to ensure that the data listed in this catalogue is correct. Challenge accepts no liability for any inaccuracies or damage caused.

FFX Tyre Couplings

FFX Tyre Coupling Data

Coupling Size	Bush Size	Max Bore		Pilot Bore	A	B	C	M *	Types F & H		Type B		Weight# kg
		Metric	Inch						F	D	F	D	
040B	-	32	-	12	104	-	82	11.0	-	-	33	22	0.84
040F	1008	25	1"	-	104	-	82	11.0	33.0	22	-	-	0.84
040H	1008	25	1"	-	104	-	82	11.0	33.0	22	-	-	0.84
050B	-	38	-	15	133	79	100	12.5	-	-	45	32.5	1.26
050F	1210	32	1.1/4"	-	133	79	100	12.5	37.5	25	-	-	1.26
050H	1210	32	1.1/4"	-	133	79	100	12.5	37.5	25	-	-	1.26
060B	-	45	-	18	165	103	124.5	16.5	-	-	55	38.5	2.10
060F	1610	42	1.5/8"	-	165	103	124.5	16.5	41.5	25	-	-	2.10
060H	1610	42	1.5/8"	-	165	103	124.5	16.5	41.5	25	-	-	2.10
070B	-	50	-	22	187	80	142	11.5	-	-	46.5	35	3.26
070F	2012	50	2"	-	187	80	142	11.5	44.5	33	-	-	3.26
070H	1610	42	1.5/8"	-	187	80	142	11.5	42.5	31	-	-	3.15
080B	-	60	-	25	211	98	165	12.5	-	-	55	42.5	5.15
080F	2517	65	2.1/2"	-	211	98	165	12.5	58.5	46	-	-	5.15
080H	2012	50	2"	-	211	98	165	12.5	45.5	33	-	-	4.83
090B	-	70	-	28	235	108	187	13.5	-	-	63.5	50	7.46
090F	2517	65	2.1/2"	-	235	108	187	13.5	59.5	46	-	-	7.35
090H	2517	65	2.1/2"	-	235	108	187	13.5	59.5	46	-	-	7.35
100B	-	80	-	32	254	120	214	13.5	-	-	70.5	57	10.4
100F	3020	75	3"	-	254	120	214	13.5	65.5	52	-	-	10.4
100H	2517	65	2.1/2"	-	254	120	214	13.5	59.5	46	-	-	9.87
110B	-	90	-	30	279	134	232	12.5	-	-	70.5	58	13.1
110F	3020	75	3"	-	279	134	232	12.5	64.5	52	-	-	12.3
110H	3020	75	3"	-	279	134	232	12.5	64.5	52	-	-	12.3
120B	-	100	-	38	314	143	262	14.5	-	-	84.5	70	17.7
120F	3525	100	4"	-	314	140	262	14.5	80.5	66	-	-	17.3
120H	3020	75	3"	-	314	140	262	14.5	66.5	52	-	-	16.7
140B	-	130	-	75	359	178	313	16.0	-	-	110	94	23.3
140F	3525	100	4"	-	359	178	313	16.0	82.0	66	-	-	23.4
140H	3525	100	4"	-	359	178	313	16.0	82.0	66	-	-	23.4
160B	-	140	-	75	402	197	347	15.0	-	-	117	102	37.6
160F	4030	115	4.1/2"	-	402	197	347	15.0	92.4	77.4	-	-	34.1
160H	4030	115	4.1/2"	-	402	197	347	15.0	92.4	77.4	-	-	34.1
180B	-	150	-	75	470	205	396	23.0	-	-	137	114	51.6
180F	4535	125	5"	-	470	205	396	23.0	112.0	89	-	-	44.3
180H	4535	125	5"	-	470	205	396	23.0	112.0	89	-	-	44.3
200B	-	150	-	85	508	206	433	24.0	-	-	138	114	61.1
200F	4535	125	5"	-	508	206	433	24.0	113.0	89	-	-	56.3
200H	4535	125	5"	-	508	206	433	24.0	113.0	89	-	-	56.3
220B	-	160	-	85	562	224	472	27.5	-	-	154.5	127	83.6
220F	5040	125	5"	-	562	224	472	27.5	129.5	102	-	-	75.6
220H	5040	125	5"	-	562	224	472	27.5	129.5	102	-	-	75.6
250B	-	190	-	88	628	254	532	28.5	-	-	160.5	132	109.0
250F	5040	125	5"	-	628	254	532	28.5	155.5	127	-	-	106.0
250H	5040	125	5"	-	628	254	532	28.5	155.5	127	-	-	106.0

Notes

= Is the weight for a half coupling.

* = M is half the distance between flange faces

NB. All flexible tyres have an angular misalignment capacity up to 4°

Fire resistant and anti static (FRAS) tyres are available

Challenge standard tyres are manufactured from natural rubber with an operating temperature span between -50°C and +50°C.

Challenge FRAS tyres are manufactured from chloroprene rubber and have an operating temperature span between -15°C and +70°C

All Challenge FFX Flanges up to size 180 are produced from forged C45 steel. From size 200 upwards are produced from GGG.

FFX Tyre Couplings

FFX Tyre Coupling Data

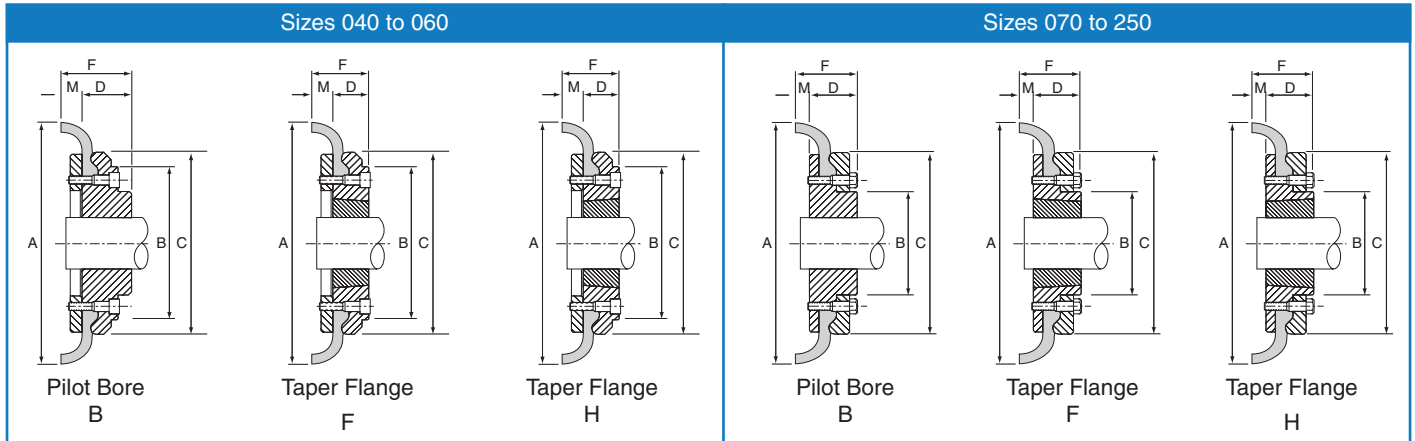

FFX Coupling Installation and Operational Data

Coupling Size	Flange Face Spacing mm	Gap Between Tyre Ends mm	Nominal Torque Nm	Max Speed rev/min	Max Parallel Misalignment mm	Max End Float* mm	Clamping Screw	
							Size	Torque Nm
40	22	2	24	4500	1.1	1.3	M6	15
50	25	2	66	4500	1.3	1.7	M6	15
60	33	2	127	4000	1.6	2.0	M6	15
70	23	3	250	3600	1.9	2.3	M8	24
80	25	3	375	3100	2.1	2.6	M8	24
90	27	3	500	3000	2.4	3.0	M10	40
100	27	3	675	2600	2.6	3.3	M10	40
110	25	3	875	2300	2.9	3.7	M10	40
120	29	3	1330	2050	3.2	4.0	M12	50
140	32	5	2325	1800	3.7	4.6	M12	55
160	30	5	3770	1600	4.2	5.3	M16	80
180	46	6	6270	1500	4.8	6.0	M16	105
200	48	6	9325	1300	5.3	6.6	M16	120
220	55	6	11600	1100	5.8	7.3	M20	165
250	59	6	14675	1000	6.6	8.2	M20	165

* End Float, alternatively called axial misalignment

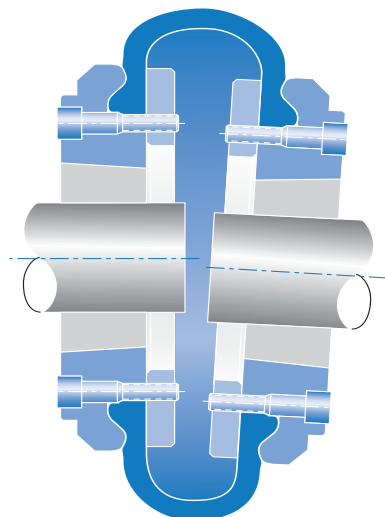

Accommodate simultaneous maximum misalignment in all planes.

FFX Tyre Coupling Installation

Installation Instructions

- 1] Clean all parts
- 2] Assemble the flanges onto the shafts after connecting the clamping rings loosely to them
- 3] Move the flanges along the shafts until dimension '2M' is obtained (see Table 3). Ensure there is sufficient gap between the shaft ends to allow for any axial movement
- 4] Check the alignment in both parallel and angular planes to ensure the shafts are aligned as accurately as possible – the more accurate the alignment, the less the tyre wear. See Table 3 for misalignment values
- 5] Fit the tyre into the gap between the flange and clamping ring, ensuring the tyre bead is correctly located. When correctly seated, the tyre gap should match the value in Table 4
- 6] Tighten the clamping ring screws alternately, and gradually, until the correct torque is achieved (see Table 3)

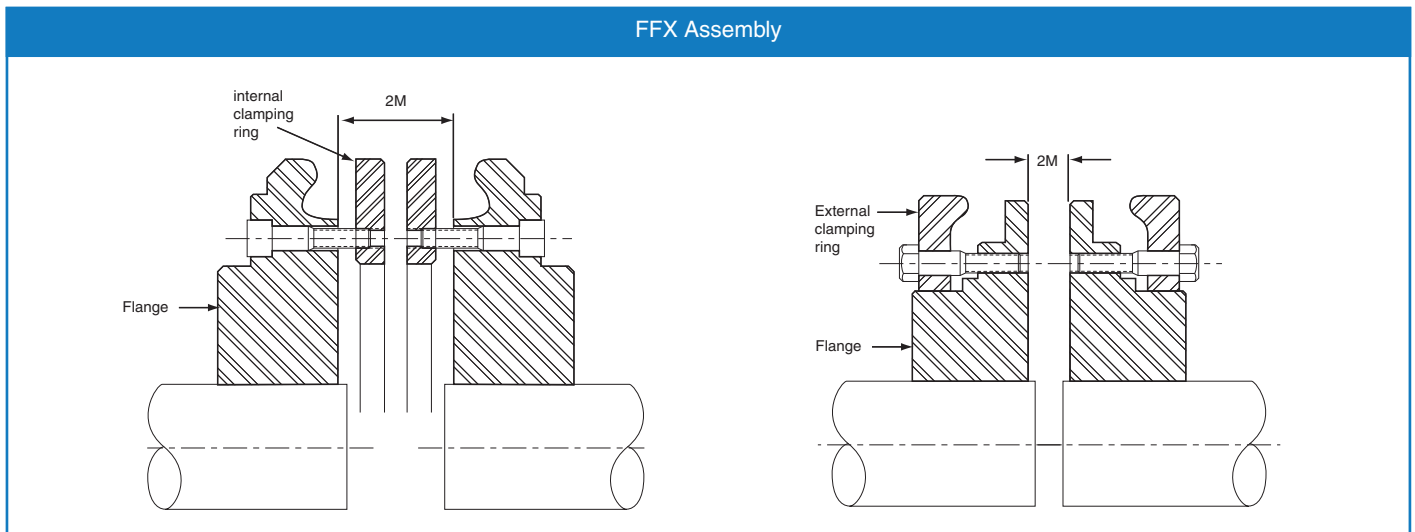

Table 3

FFX Coupling size	040	050	060	070	080	090	100	110	120	140	160	180	200	220	250
Parallel misalignment	1.0	1.3	1.6	1.9	2.1	2.4	2.6	2.9	3.2	3.7	4.2	4.8	5.3	5.8	6.6
Axial (end float) misalignment	1.3	1.7	2.0	2.3	2.6	3.0	3.3	3.7	4.0	4.6	5.3	6.0	6.6	7.3	8.2
Angular misalignment	4°	4°	4°	4°	4°	4°	4°	4°	4°	4°	4°	4°	4°	4°	4°
'2M' dimension	22	25	33	23	25	27	27	25	29	32	30	46	48	55	59
Clamping ring screw torque - Nm	15	15	15	24	24	40	40	40	50	55	80	105	120	165	165

Table 4

FFX Coupling Size	040 to 060	070 to 120	140 to 160	180 to 250
Gap between tyre ends	2	3	5	6

All dimensions in millimetres unless otherwise stated. Every effort has been taken to ensure that the data listed in this catalogue is correct. Challenge accepts no liability for any inaccuracies or damage caused.

HRC Couplings

HRC Coupling selection procedure

- 1] **Service Factor**
from Table 1 on page 252, select the service factor that is appropriate for the application
- 2] **Design Power**
Multiply the absorbed power of the driven machine, in kW, by the service factor, from step 1) to obtain the design power. If the absorbed power is not known, use the prime mover power.
- 3] **HRC coupling size selection**
Refer to Table 2 on page 252.
Read down the left hand vertical column to the required speed. Interpolate if the exact speed is not listed
Read horizontally across on the speed line until a power equal to or in excess of the design power, from step 2), is reached
Read vertically to the top of the column to obtain the correct size of HRC coupling.
- 4] **Bore dimensions**
From the dimension Tables on page 253, check that the selected coupling will fit the shafts.

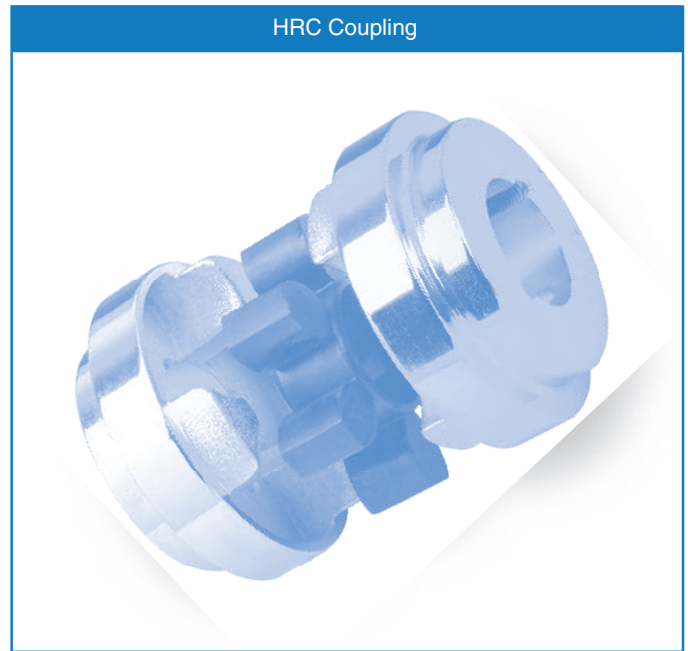

HRC Coupling selection example

Select a Challenge HRC coupling to couple an 11 kW, 970 rev/min motor to a machine tool which has to run for 17 hours/day. The motor shaft is 42 mm diameter and the machine tool shaft 38 mm diameter
Taper bush flanges are required for both shafts.

- 1] **Service factor**
From Table 1 on page 252, the service factor for this application is 2.00
- 2] **Design power**
As the machine tool absorbed power is not known, the motor power is used as a basis for selecting the coupling.
The design power is $11 \times 2.00 = 22.0 \text{ kW}$
- 3] **HRC coupling size selection**
Refer to Table 2 on page 252.
By reading down and interpolating for the required speed of 970 rev/min, it is seen that an HRC 130 will transmit 32.0 kW which is in excess of the 22.0 kW required from step 2)
- 4] **Bore dimensions**
From the dimension Table on page 253, the flanges on an HRC 130 take 1610 taper bushes which are available with bores to suit the shaft requirements of the application.

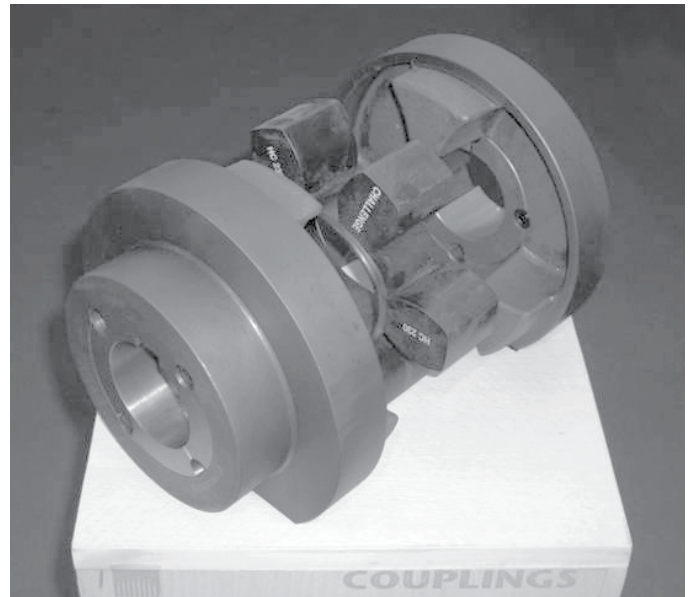

HRC Coupling Selection

Table 1, Service Factors

Special cases For applications where shock, vibration and torque fluctuations occur – consult Challenge Type of driven machine	Type of prime mover					
	‘Soft’ Starts			‘Heavy’ Starts		
	Electric motors and other smooth running prime movers			Internal Combustion Engines		
	Number of hours per day running					
	10 and under	over 10 - 16 incl	over 16	10 and under	over 10 - 16 incl	over 16
Uniform load Light duty agitators, belt conveyors for sand etc., fans up to 7.5 kW, centrifugal compressors and pumps,	1.0	1.12	1.25	1.25	1.40	1.60
Moderate load Variable density agitators, belt conveyors (non-uniform loads), fans over 7.5 kW, other rotary compressors and pumps, machine tools, printing machinery, laundry machinery, rotary screens, rotary woodworking machinery	1.5	1.75	2.00	2.00	2.25	2.50
Heavy load Reciprocating compressors and pumps, positive displacement blowers, heavy duty conveyors such as screw, bucket etc., hammer mills, pulverisers, presses, shears, punches, rubber machinery, crushers, metal mills	2.50	2.75	3.00	3.00	3.50	4.00

Table 2, Power Ratings (kW)

Rotational speed in rev/min	70	90	110	130	150	180	230	280
100	0.33	0.84	1.68	3.30	6.28	9.95	20.9	33.0
500	1.65	4.20	8.40	16.5	31.4	49.8	105	165
700	2.31	5.88	11.8	23.1	44.0	69.7	146	231
720	2.37	6.05	12.1	23.8	45.2	71.6	150	238
800	2.64	6.72	13.4	26.4	50.3	79.6	167	264
900	2.97	7.56	15.1	29.7	56.5	89.6	188	297
960	3.17	8.06	16.1	31.7	60.3	95.5	201	317
1000	3.33	8.40	16.8	33.0	62.8	99.5	209	330
1200	3.96	10.1	20.2	39.6	75.4	119	251	396
1400	4.62	11.8	23.5	46.2	87.9	139	293	462
1440	4.75	12.1	24.2	47.5	90.4	143	301	475
1500	4.95	12.6	25.2	49.5	94.2	149	314	495
1800	5.94	15.1	30.2	59.4	113	179	376	594
2000	6.60	16.8	33.6	66.0	126	199	418	660
2500	8.25	21.0	42.0	82.5	157	249	523	-
2880	9.50	24.2	48.4	95.0	181	287	-	-
3000	9.90	25.2	50.4	99.0	188	299	-	-
3500	11.6	29.4	58.8	116	220	348	-	-
4000	13.2	33.6	67.2	132	251	-	-	-
4500	14.9	37.8	75.6	149	283	-	-	-
5000	16.5	42.0	84.0	-	-	-	-	-

All power ratings are constant torque
Interpolate for speeds not listed

HRC Couplings

HRC Common Data

Coupling Size	Nominal Torque Nm	Overall Diameter A	Hub Diameter B	Assembled Length F	Element		Parallel Misalignment	Weight kg	Assembled Length (L)		
					Ring Dia E	Ring Width G			FF, FH, HH	FB,HB	BB
70	31	69	60	25.5	31	18.5	0.3	1.00	65.5	65.5	65.5
90	80	85	70	30.5	32	22.5	0.3	1.17	69.5	76.5	82.5
110	160	112	100	45.5	45	29.5	0.3	5.00	82.5	100.5	119.5
130	315	130	105	53.5	50	36.5	0.4	5.46	89.5	110.5	131.5
150	600	150	115	60.5	62	40.5	0.4	7.11	107.5	129.5	152.5
180	950	180	125	73.5	77	49.5	0.4	16.65	142.5	165.5	189.5
230	2000	225	155	85.5	99	59.5	0.5	26.05	164.5	202.5	239.5
280	3150	275	206	105.5	119	74.5	0.5	50.05	207.5	246.5	285.5

Angular misalignment capacity up to 1 deg

Weight is for an FF, FH or HH coupling with mid range Taper Bushes
F refers to combinations of flanges: FF, FH, HH, FB, HB, BB.

The elastomeric element in Challenge HRC couplings is manufactured from nitrile rubber with an operating temperature span between -40°C and +100°C.

HRC Type F & H

Coupling No	Bush size	Max. Bore		Shoulder Width D	Hub Width C
		mm	inch		
70	1008	25	1"	20.0	23.5
90	1108	28	1.1/8"	19.5	23.5
110	1610	42	1.5/8"	18.5	26.5
130	1610	42	1.5/8"	18.0	26.5
150	2012	50	2"	23.5	33.5
180	2517	65	2.1/2"	34.5	46.5
230	3020	75	3"	39.5	52.5
280	3525	100	4"	51.0	66.5

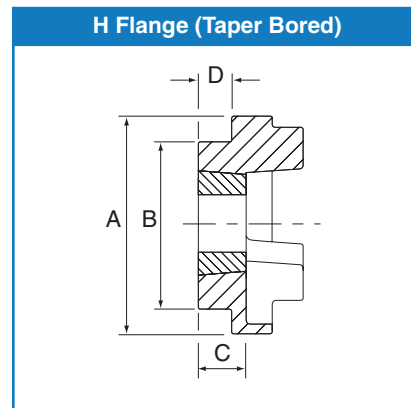
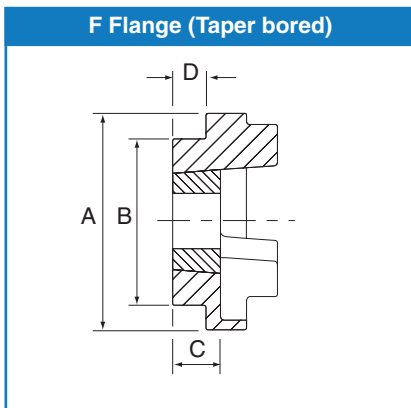
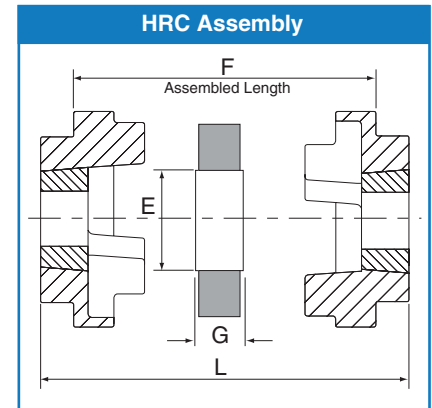

HRC Type B (Pilot Bore)

Coupling No	Max. Bore	Pilot Bore	Keyway Screw Size	Shoulder Width D	Hub Width C
70	32	8	M 6	20	23.5
90	42	10	M 6	26	30.5
110	55	10	M10	37	45.5
130	60	15	M10	39	47.5
150	70	20	M10	46	56.5
180	80	25	M10	58	70.5
230	100	25	M12	77	90.5
280	115	30	M16	90	105.5

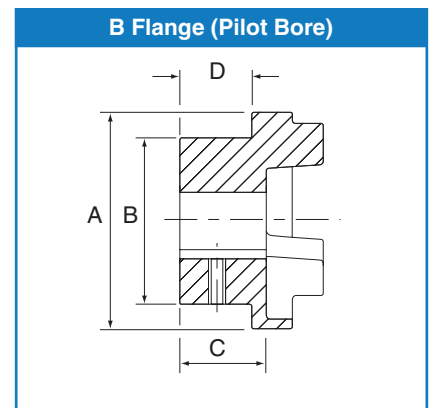

NPX Couplings

NPX Coupling selection procedure

Based on Power and Speed

1] Service Factor

From Table 1 on page 255, select the service factor that is appropriate for the application

2] Design Power

Multiply the absorbed power, kW, of the driven machine by the service factor, from step 1) to obtain the design power.
If the absorbed power is not known, use the prime mover power.

3] NPX coupling size selection

Refer to Table 2 on page 255.

Read down the left hand vertical column to the required speed.
Interpolate if the exact speed is not listed
Read horizontally across on the speed line until a power equal to or in excess of the design power, from step 2), is reached.
Read vertically to the top of the column to obtain the correct size of NPX coupling.

4] Bore dimensions

From the dimension Tables on pages 257 and 258, check that the selected coupling will fit the shafts.

Based on IEC Electric Motors (page 256)

- 1] Note the frame size of the motor, power, speed (or number of poles)
- 2] Read across to the column headed by the motor speed (or number of poles)
- 3] The next column to the motor power gives the size of NPX coupling required
Pilot bore flange sizes are in normal type face. Taper bore flanges are in italic

NPX coupling selection example

Select a Challenge NPX coupling to couple a 15.0 kW, 1460 rev/min motor to a pulveriser which absorbs 13.2 kW.

Both shaft diameters are 42 mm and Taper bush flanges are required for both shafts.

1] Service factor

from Table 1 on page 255, the service factor for this application is 1.75

2] Design power

using the absorbed power of the pulveriser, the design power is
 $13.2 \times 1.75 = 23.1 \text{ kW}$

3] NPX coupling size selection

Refer to Table 2 on page 255

By reading down and interpolating for the required speed of 1460 rev/min, it is seen that an NPX size 110 will transmit 24.5 kW which is in excess of the 23.1 kW required from step 2)

4] Bore dimensions

from the dimension Table on page 258, the flanges on an NPX 110 take a 1610 taper bush which are available with bores to suit the shaft requirements of the application



NPX Coupling Selection

Table 1, Service Factors

Special cases For applications where shock, vibration and torque fluctuations occur – consult Challenge	Type of prime mover		
	Electric motors and other smooth running devices	Internal combustion engines with 4 or more cylinders	Internal combustion engines with less than 4 cylinders
Type of driven machine			
Uniform load Light duty agitators, belt conveyors for sand etc., fans upto 7.5 kW, centrifugal compressors and pumps, generators	1.00	1.25	1.50
Moderate load Variable density agitators, belt conveyors (non-uniform loads), fans over 7.5 kW, other rotary compressors and pumps, machine tools, printing machinery, laundry machinery, rotary screens, rotary woodworking machinery	1.25	1.50	2.00
Heavy load Reciprocating compressors and pumps, positive displacement blowers, heavy duty conveyors such as screw, bucket etc., hammer mills, pulverisers, presses, shears, punches, rubber machinery, crushers, metal mills	1.75	2.00	2.50

The above Service Factors are based on 24 hours/day duty

Table 2, Power Ratings (kW)

Rotational speed in rev/min	58	68	80	95	110	125	140	160	180	200	225	250
100	0.20	0.36	0.63	1.05	1.68	2.51	3.77	5.86	9.22	14.0	20.9	29.3
500	1.00	1.80	3.15	5.25	8.40	12.6	18.9	29.3	46.1	70.2	105	147
700	1.40	2.52	4.41	7.35	11.8	17.6	26.4	41.0	64.5	98.2	147	205
720	1.44	2.59	4.54	7.56	12.1	18.1	27.1	42.2	66.4	101	151	211
800	1.60	2.88	5.04	8.40	13.4	20.1	30.2	46.9	73.8	112	168	235
900	1.80	3.24	5.67	9.45	15.1	22.6	33.9	52.7	83.0	126	188	264
960	1.92	3.46	6.05	10.1	16.1	24.1	36.2	56.3	88.5	135	201	281
1000	2.00	3.60	6.30	10.5	16.8	25.1	37.7	58.6	92.2	140	209	293
1200	2.40	4.32	7.56	12.6	20.2	30.1	45.2	70.3	111	168	251	352
1400	2.80	5.04	8.82	14.7	23.5	35.1	52.8	82.0	129	196	293	410
1440	2.88	5.18	9.07	15.1	24.2	36.1	54.3	84.4	133	202	302	422
1500	3.00	5.40	9.45	15.8	25.2	37.7	56.6	87.9	138	210	314	440
1800	3.60	6.48	11.3	18.9	30.2	45.2	67.9	105	166	253	377	528
2000	4.00	7.20	12.6	21.0	33.6	50.2	75.4	117	184	281	419	586
2500	5.00	9.00	15.8	26.3	42.0	62.8	94.3	147	231	351	524	733
2880	5.76	10.4	18.1	30.2	48.4	72.3	109	169	266	404	603	-
3000	6.00	10.8	18.9	31.5	50.4	75.3	113	176	277	421	628	-
3500	7.00	12.6	22.1	36.8	58.8	87.9	132	205	323	-	-	-
4000	8.00	14.4	25.2	42.0	67.2	100	151	234	-	-	-	-
4500	9.00	16.2	28.4	47.3	75.6	113	170	-	-	-	-	-
5000	10.0	18.0	31.5	52.5	84.0	126	-	-	-	-	-	-

All power ratings are constant torque
Interpolate for speeds not listed

NPX Coupling Selection

IEC motor selection Table (50Hz)

Frame size, shaft diameter and length			Motor power (kW) 2-pole 3000 rev/min	NPX size *	Motor power (kW) 4-pole 1500 rev/min	NPX size *	Motor power (kW) 6-pole 1000 rev/min	NPX size *	Motor power (kW) 8-pole 750 rev/min	NPX size *
	2 pole	4, 6, 8 pole								
80	19 x 40		0.75	58 / 80	0.55	58 / 80	0.37	58 / 80	0.18	
			1.1	58 / 80	0.75	58 / 80	0.55	58 / 80	0.25	
90S	24 x 50		1.5	68 / 80	1.1	68 / 80	0.75	68 / 80	0.37	
90L			2.2	68 / 80	1.5	68 / 80	1.1	68 / 80	0.55	
100L	28 x 60		3.0	80 / 80	2.2	80 / 80	1.5	80 / 80	0.75	80 / 80
					3.0				1.1	80 / 80
112M			4.0	80 / 80	4.0	80 / 80	2.2	80 / 80	1.5	80 / 80
132S	38 x 80		5.5	95 / 110	5.5	95 / 110	3.0	95 / 110	2.2	95 / 110
			7.5	95 / 110		95 / 110				
132M					7.5		4.0	95 / 110	3.0	95 / 110
							5.5	95 / 110		
160M	42 x 110		11	95 / 110	11	95 / 110	7.5	95 / 110	4.0	95 / 110
			15	95 / 110					5.5	95 / 110
160L			18.5	95 / 110	15	110 / 110	11	110 / 110	7.5	110 / 110
180M	48 x 110		22	110 / 125	18.5	110 / 125				
180L					22	125 / 125	15	125 / 125	11	125 / 125
200L	55 x 110		30	125 / 160	30	125 / 160	18.5	125 / 160	15	125 / 160
			37	125 / 160			22	140 / 160		
225S	55 x 110	60 x 140		125 / 160	37	140 / 160			18.5	140 / 160
225M			45	125 / 160	45	140 / 160	30	140 / 160	22	140 / 160
250M	60 x 140	65 x 140	55	140 / 160	55	160 / 160	37	160 / 160	30	160 / 160
280S	75 x 140		75	160 / 160	75	<i>200</i>	45	<i>200</i>	37	<i>250</i>
280M			90	160 / 160	90	<i>200</i>	55	<i>200</i>	45	<i>250</i>
315S	80 x 170		110	160 / 160	110	<i>250</i>	75	<i>250</i>	55	<i>250</i>
315M			132	160 / 160	132		90	<i>250</i>	75	<i>250</i>
315L	65 x 140		160	160 / 160	160		110	<i>250</i>	90	<i>250</i>
			200		200		132	<i>250</i>	110	<i>250</i>
315	85 x 170						160	<i>250</i>	132	<i>250</i>
			250		250	<i>250</i>	200			

The above selection procedure is based on the following parameters:-

- Service factor of 1.25
- No more than 25 starts per hour

If the parameters differ from the above, the selection should be based on power and speed

* Pilot bore flanges are in **bold normal** type face

* Taper bore flanges are in *light italic* type face

NPX Couplings

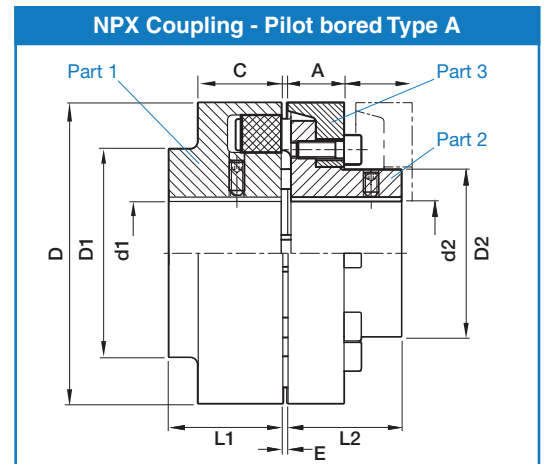
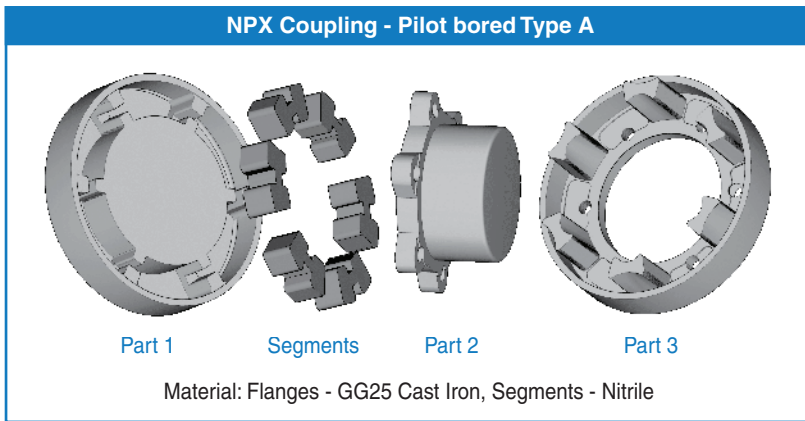

Pilot bored Type A

Size	Power at 100 rev/min kW	Torque		Max Speed rev/min	Maximum bore		D parts 1 and 3	L1 part 1	L2 part 2	D1 part 1	D2 part 2	A part 3	C part 1	E	Weight of flange kg		
		Rated Nm	Max Nm		d1 part 1	d2 part 2									flange part 1	flange part 2	flange part 3
110	1.68	160	480	5000	48	38	110	40	40	86	62	20.0	34	2 - 4	1.95	1.38	1.97
125	2.51	240	720	5000	55	45	125	50	50	100	75	23.5	36	2 - 4	3.05	2.42	1.97
140	3.77	360	1080	4900	60	50	140	55	55	100	82	28.0	34	2 - 4	3.65	3.04	2.50
160	5.86	560	1680	4250	65	58	160	60	60	108	95	28.0	40	2 - 6	5.05	4.19	3.49
180	9.22	880	2640	3800	75	65	180	70	70	125	108	30.0	42	2 - 6	7.80	5.94	4.41
200	14.03	1340	4020	3400	85	75	200	80	80	140	122	32.5	47	2 - 6	11.0	8.61	6.02
225	20.94	2000	6000	3000	90	85	225	90	90	150	138	38.0	52	2 - 6	15.0	12.06	8.93
250	29.32	2800	8400	2750	100	95	250	100	100	165	155	42.0	60	3 - 8	19.5	17.41	11.70

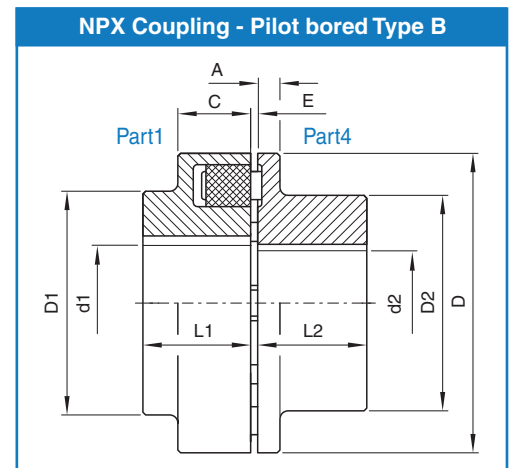
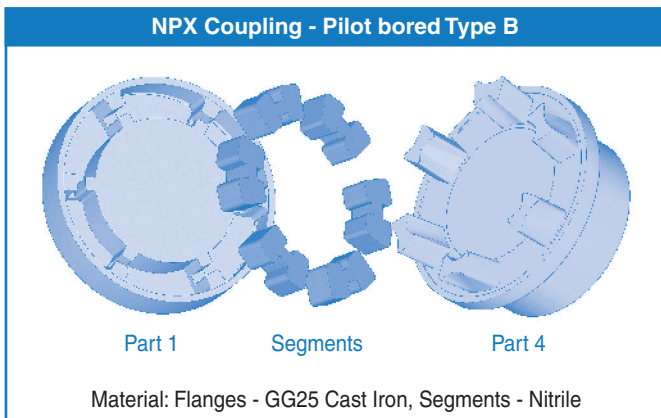

Pilot bored Type B

Size	Power at 100 rev/min kW	Torque		Max Speed rev/min	Maximum bore		D parts 1 and 4	L1 part 1	L2 part 4	D1 part 1	D2 part 4	A part 4	C part 1	E	Weight of flange kg	
		Rated Nm	Max Nm		d1 part 1	d2 part 4									part 1	part 4
58	0.20	19	57	5000	19	24	58	20	20	-	40	8	20	2 - 4	0.24	0.28
68	0.36	34	102	5000	24	28	68	20	20	-	49	8	20	2 - 4	0.32	0.45
80	0.63	60	180	5000	30	38	80	30	30	-	68	10	30	2 - 4	0.75	0.94
95	1.05	100	300	5000	42	42	95	35	36	76	76	13	30	2 - 4	1.30	1.55
110	1.68	160	480	5000	48	48	110	40	40	86	86	14	34	2 - 4	1.95	2.25
125	2.51	240	720	5000	55	55	125	50	50	100	100	18	36	2 - 4	3.05	3.60
140	3.77	360	1080	4900	60	60	140	55	55	100	100	20	34	2 - 4	3.65	4.50
160	5.86	560	1680	4250	65	65	160	60	60	108	108	20	40	2 - 6	5.05	5.95
180	9.22	880	2640	3800	75	75	180	70	70	125	125	20	42	2 - 6	7.80	8.50
200	14.03	1340	4020	3400	85	85	200	80	80	140	140	24	47	2 - 6	11.0	12.4
225	20.94	2000	6000	3000	90	90	225	90	90	150	150	18	52	2 - 6	15.0	15.5
250	29.32	2800	8400	2750	100	100	250	100	100	165	165	18	60	3 - 8	19.5	19.5

Weight and inertia figures are for a mid range bore.

Temperature range -30°C to 75°C

Every effort has been taken to ensure that the data listed in this catalogue is correct. Challenge accepts no liability for any inaccuracies or damage caused. All dimensions in millimetres unless otherwise stated.

NPX Couplings

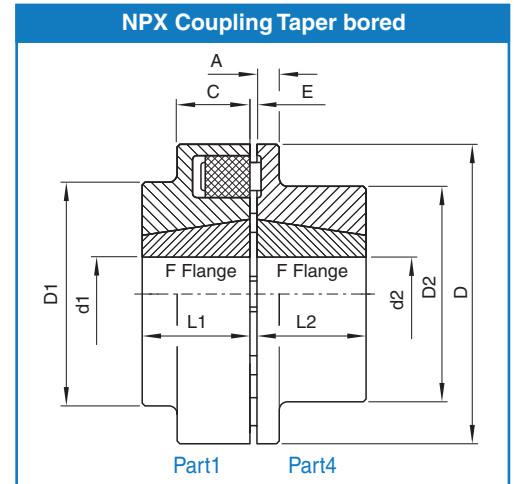
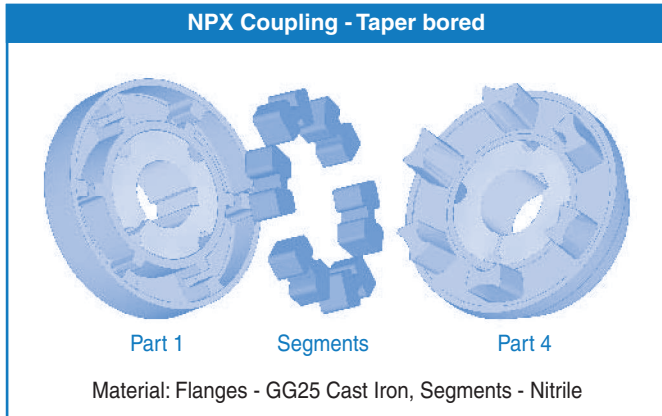

Taper bored

Size	Power at 100 rev/min kW	Torque		Max speed rev/min	Bush for F flange	Max bore d1/d2 parts 1 and 4	D parts 1 and 4	L1 part 1	L2 part 4	D1 part 1	D2 part 4	A part 4	C part 1	E	Weight of flange kg	
		rated Nm	max Nm												flange part 1	flange part 4
80	0.63	60	180	5000	1108	28	80	22.5	22.5	0	0	22.5	22.5	2 - 4	0.75	0.94
95	1.05	100	300	5000	1210	32	95	26.5	26.5	0	76	13.0	26.5	2 - 4	1.30	1.55
110	1.68	160	480	5000	1615	42	110	38.5	38.5	86	86	14.0	34.0	2 - 4	1.95	2.25
125	2.51	240	720	5000	2012	50	125	32.5	32.5	0	100	18.0	32.5	2 - 4	3.05	3.60
140	3.77	360	1080	4900	2012	50	140	32.5	32.5	0	100	20.0	32.5	2 - 4	3.65	4.50
160	5.86	560	1680	4250	2517	65	160	46.0	46.0	108	108	20.0	40.0	2 - 6	5.05	5.95
180	9.22	880	2640	3800	2517	65	180	46.0	46.0	125	125	20.0	42.0	2 - 6	7.80	8.50
200	14.03	1340	4020	3400	3020	75	200	52.0	52.0	140	140	24.0	47.0	2 - 6	11.0	12.4
225	20.94	2000	6000	3000	3020	75	225	52.0	52.0	150	150	18.0	52.0	2 - 6	15.0	15.5
250	29.32	2800	8400	2750	3535	90	250	90.0	90.0	165	165	18.0	60.0	3 - 8	19.5	19.5

Weight and inertia figures are for a mid range bore.

Temperature range -30°C to 75°C

RPX Couplings

RPX Coupling selection procedure Based on Power and Speed

- 1] **Service Factor**
From Table 1 on page 260, select the service factor that is appropriate for the application
- 2] **Design Power**
Multiply the absorbed power, kW, of the driven machine by the service factor, from step 1) to obtain the design power. If the absorbed power is not known, use the prime mover power.
- 3] **RPX coupling size selection**
Refer to Table 2 on page 261 and select either the standard 92 shore spider or the higher torque 98 shore spider. Read down the left hand vertical column to the required speed. (Interpolate if the exact speed is not listed). Read horizontally across on the speed line until a power equal to or in excess of the design power, from step 2), is reached. Read vertically to the top of the column to obtain the correct size of RPX coupling.
- 4] **Bore dimensions**
From the dimension Tables on page 263, check that the selected coupling will fit the shafts.

Based on IEC Electric Motors, see page 262

- 1] Note the frame size of the motor, power, speed (or number of poles)
- 2] Read across to the column headed by the motor speed (or number of poles)
- 3] The next column to the motor power gives the size of RPX coupling required

RPX Coupling selection example

Select a Challenge RPX coupling to couple an 11.0 kW, 1450 rev/min motor to a hammer mill which absorbs 9.6 kW running for 12 hours per day with no more than 30 stops/starts per hour. A good shock absorbing spider is required for this heavy duty application.

The ambient temperature is + 38°C. The motor shaft is 42mm diameter and the kiln shaft 38mm.

- 1] **Service factor**
From Table 1 on page 260, the service factor for this application is: $1.75 \times 1.2 \times 1.0 = 2.1$
- 2] **Design power**
The design power is $9.6 \times 2.1 = 20.2$ kW

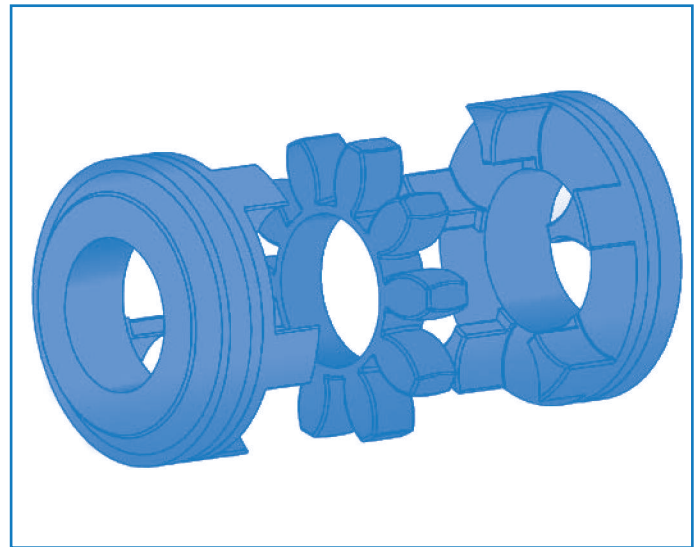
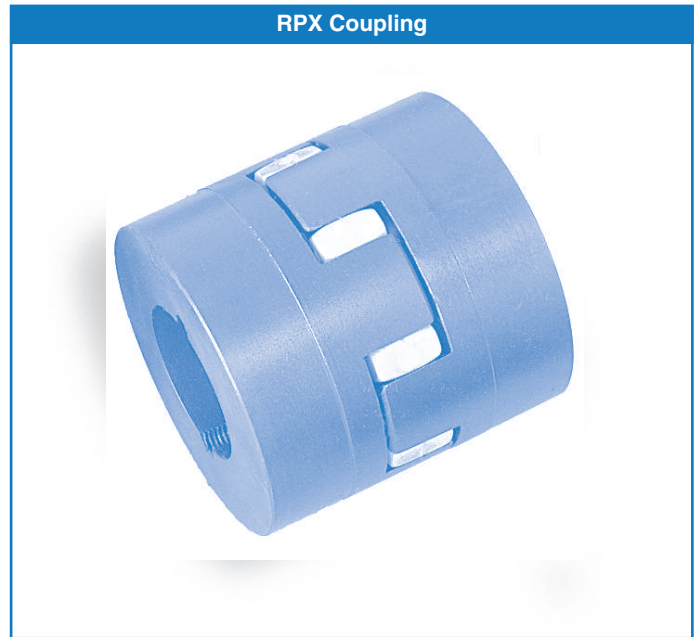

- 3] **RPX coupling size selection**
Because of its shock absorbing characteristics, the 92 shore spider is chosen: Refer to Table 2 on page 261

By reading down and interpolating for the required speed of 1450 rev/min, it is seen that an RPX size 38 will transmit 28.9 kW which is in excess of the 20.2 kW required from step 2)
- 4] **Bore dimensions**
From the dimension Tables on page 263, the flanges on an RPX 38 take an 1108 taper bush with a maximum bore of 28mm. Therefore, pilot bore flanges will be required as follows: Flange Type 1 bored 38mm and flange Type 1a bored 42mm

If taper bore flanges are required then a RPX size 42 will have to be used. The RPX size 42 utilises a 1610 taper bush with a maximum bore of 42mm.

RPX Coupling Selection

Table 1, Service Factors

Special cases For applications where shock, vibration and torque fluctuations occur – consult Challenge	Type of prime mover		
	Type of driven machine	Electric motors and other smooth running devices	Internal combustion engines with 4 or more cylinders
Uniform load Light duty agitators, belt conveyors for sand etc., fans up to 7.5 kW, centrifugal compressors and pumps,	1.0	1.25	1.50
Moderate load Variable density agitators, belt conveyors (non-uniform loads), fans over 7.5 kW, other rotary compressors and pumps, machine tools, printing machinery, laundry machinery, rotary screens, rotary woodworking machinery	1.25	1.50	2.00
Heavy load Reciprocating compressors and pumps, positive displacement blowers, heavy duty conveyors such as screw, bucket etc., hammer mills, pulverisers, presses, shears, punches, rubber machinery, crushers, metal mills	1.75	2.00	2.50

The above Service Factors are based on 24 hours/day duty

Additional service factor multiplier for temperature : -30°C to +30° = 1.00, +40°C = 1.2, +60°C = 1.4, +80°C = 1.8

Additional frequent start multiplier : up to 100 starts/hour = 1.0 100-200 = 1.2 200-400= 1.4 400-800=1.6

Challenge elements are manufactured from polyurethane with an operating temperature span between -40°C to +100°C.

They can also accommodate transient temperatures up to +120°C

RPX Coupling Selection

Table 2, Power Ratings (kW) for 92 shore elements (Yellow)

Rotational speed in rev/min	19	24	28	38	42	48	55	65	75	90
100	0.10	0.37	1.00	1.99	2.78	3.25	4.29	6.55	13.4	25.1
500	0.52	1.83	4.98	9.95	13.9	16.2	21.5	32.7	67.0	126
700	0.73	2.56	6.97	13.9	19.4	22.7	30.1	45.8	93.8	176
720	0.75	2.64	7.16	14.3	20.0	23.4	30.9	47.1	96.5	181
800	0.84	2.93	7.96	15.9	22.2	26.0	34.3	52.4	107	201
900	0.94	3.29	8.96	17.9	25.0	29.2	38.6	58.9	121	226
960	1.01	3.51	9.55	19.1	26.6	31.2	41.2	62.8	129	241
1000	1.05	3.66	9.95	19.9	27.8	32.5	42.9	65.5	134	251
1200	1.26	4.39	11.9	23.9	33.3	39.0	51.5	78.5	161	302
1400	1.47	5.12	13.9	27.9	38.9	45.4	60.1	91.6	188	352
1440	1.51	5.27	14.3	28.7	40.0	46.7	61.8	94.2	193	362
1500	1.57	5.49	14.9	29.9	41.6	48.7	64.4	98.2	201	377
1800	1.88	6.59	17.9	35.8	50.0	58.4	77.3	118	241	452
2000	2.09	7.32	19.9	39.8	55.5	64.9	85.9	131	268	503
2500	2.62	9.15	24.9	49.8	69.4	81.2	107	164	335	628
2880	3.02	10.5	28.7	57.3	79.9	93.5	124	188	386	724
3000	3.14	11.0	29.9	59.7	83.3	97.4	129	196	402	754
3500	3.66	12.8	34.8	69.7	97.1	114	150	229	469	880
4000	4.19	14.6	39.8	79.6	111	130	172	262	536	-
4500	4.71	16.5	44.8	89.6	125	146	193	295	603	-
5000	5.24	18.3	49.8	99.5	139	162	215	327	-	-

All power ratings are constant torque
Interpolate for speeds not listed

92 shore (yellow) are the standard elements and 98 shore (red) elements can be used for higher torques.

Table 2, Power Ratings (kW) for 98 shore elements (Red)

Rotational speed in rev/min	19	24	28	38	42	48	55	65	75	90
100	0.18	0.63	1.68	3.40	4.71	5.50	7.17	9.84	20.1	37.7
500	0.89	3.14	8.38	17.0	23.6	27.5	35.9	49.2	101	189
700	1.25	4.40	11.7	23.8	33.0	38.5	50.2	68.9	141	264
720	1.28	4.52	12.1	24.5	33.9	39.6	51.6	70.9	145	271
800	1.42	5.02	13.4	27.2	37.7	44.0	57.4	78.7	161	302
900	1.60	5.65	15.1	30.6	42.4	49.5	64.6	88.6	181	339
960	1.71	6.03	16.1	32.7	45.2	52.8	68.9	94.5	193	362
1000	1.78	6.28	16.8	34.0	47.1	55.0	71.7	98.4	201	377
1200	2.14	7.54	20.1	40.8	56.5	66.0	86.1	118	241	452
1400	2.49	8.79	23.5	47.6	66.0	77.0	100	138	281	528
1440	2.56	9.04	24.1	49.0	67.9	79.2	103	142	290	543
1500	2.67	9.42	25.1	51.0	70.7	82.5	108	148	302	566
1800	3.20	11.3	30.2	61.3	84.8	98.9	129	177	362	679
2000	3.56	12.6	33.5	68.1	94.2	110	143	197	402	754
2500	4.45	15.7	41.9	85.1	118	137	179	246	503	943
2880	5.13	18.1	48.2	98.0	136	158	207	283	579	1086
3000	5.34	18.8	50.3	102	141	165	215	295	603	1131
3500	6.23	22.0	58.6	119	165	192	251	345	704	1320
4000	7.12	25.1	67.0	136	188	220	287	394	804	-
4500	8.01	28.3	75.4	153	212	247	323	443	905	-
5000	8.90	31.4	83.8	170	236	275	359	492	-	-

All power ratings are constant torque
Interpolate for speeds not listed

92 shore (yellow) are the standard elements and 98 shore (red) elements can be used for higher torques.

RPX Coupling Selection

IEC Motor Selection Table (50Hz)

Frame size shaft diameter and length		Motor power (kW) 2-pole 3000 rev/min	RPX size *	Motor power (kW) 4-pole 1500 rev/min	RPX size *	Motor power (kW) 6-pole 1000 rev/min	RPX size *	Motor power (kW) 8-pole 750 rev/min	RPX size *	
	2 pole	4, 6, 8 pole								
80	19 x 40		0.75	19 / 24	0.55	19 / 24	0.37	19 / 24	0.18	19 / 24
			1.1	19 / 24	0.75	19 / 24	0.55	19 / 24	0.25	19 / 24
90S	24 x 50		1.5	19 / 24	1.1	19 / 24	0.75	19 / 24	0.37	19 / 24
90L			2.2	19 / 24	1.5	19 / 24	1.1	19 / 24	0.55	19 / 24
100L	28 x 60		3.0	24 / 28	2.2	24 / 28	1.5	24 / 28	0.75	24 / 28
					3.0	24 / 28			1.1	24 / 28
112M	38 x 80		4.0	24 / 28	4.0	24 / 28	2.2	24 / 28	1.5	24 / 28
132S			5.5	28 / 42	5.5	28 / 42	3.0	28 / 42	2.2	28 / 42
			7.5	28 / 42						
132M					7.5	28 / 42	4.0	28 / 42	3.0	28 / 42
							5.5	28 / 42		
160M	42 x 110		11	38 / 42	11	38 / 42	7.5	38 / 42	4.0	38 / 42
			15	38 / 42					5.5	38 / 42
160L			18.5	38 / 42	15	38 / 42	11	38 / 42	7.5	38 / 42
180M	48 x 110		22	38 / 42	18.5	42 / 55				
180L					22	42 / 55	15	42 / 55	11	42 / 55
200L	55 x 110		30	42 / 65	30	42 / 65	18.5	42 / 65	15	42 / 65
			37	42 / 65			22	42 / 65		
225S	55 x 110	60 x 140			37	48 / 65			18.5	48 / 65
225M			45	42 / 65	45	55 / 65	30	55 / 65	22	55 / 65
250M	60 x 140	65 x 140	55	48 / 65	55	55 / 65	37	65 / 65	30	65 / 65
280S		75 x 140	75	48 / 65	75	65 / 75	45	65 / 75	37	65 / 75
280M			90	48 / 65	90	75 / 75	55	75 / 75	45	75 / 75
315S		80 x 170	110	65 / 65	110	75 / 90	75	75 / 90	55	75 / 90
315M	65 x 140		132	65 / 65	132	75 / 90	90	75 / 90	75	90 / 90
			160	65 / 65	160	90 / 90	110	90 / 90	90	90 / 90
315L			200	75 / 75	200	90 / 90	132	90 / 90	110	90 / 90
							160	90 / 90	132	90 / 90
315		85 x 170	250	75 / 75	250	90 / 90	200	90 / 90		

The above selection procedure is based on the following parameters:-

- Service factor of 2.0
- 30° C maximum temperature
- 92 Shore insert
- 100 starts per hour maximum

If the parameters differ from the above, selection should be based on power and speed

* Pilot bore flanges are in **bold normal** type face

* Taper bore flanges are in *light italic* type face

RPX Coupling Selection

RPX Coupling Data - Pilot bored

TYPE	Max Speed rev/min	Rated Torque		D	D ₁	d-min	d-max	S	L ₁	L ₂	L	Material	Weight kg/hub
		92 shore Nm	98 shore Nm										
19 1	19000	10	17	40	32	6	19	1.0	39.0	25	65	Al	0.19
1a				40	-	19	24	1.0	39.0	25	65	Al	-
24 1	14000	35	60	56	40	9	24	1.0	46.0	30	77	Al	0.38
1a				56	-	22	28	1.0	46.0	30	77	Al	-
28 1	11800	95	160	65	48	10	28	1.5	52.5	35	89	Al	0.62
1a				65	-	28	38	1.5	52.5	35	89	Al	-
38 1	9500	190	325	80	66	12	38	1.0	66.0	45	112	CI	1.36
1a				80	-	38	45	1.0	66.0	45	112	CI	-
42 1	8000	265	450	95	75	14	42	1.0	73.0	50	124	CI	2.03
1a				95	-	42	55	1.0	73.0	50	124	CI	-
48 1	7100	310	525	105	85	15	48	1.5	80.5	56	138	CI	2.85
1a				105	-	48	60	1.5	80.5	56	138	CI	-
55 1	6300	410	685	120	98	20	55	2.0	91.0	65	158	CI	4.32
1a				120	-	55	70	2.0	91.0	65	158	CI	-
65 1	5600	625	940	135	115	20	65	1.5	105.5	75	182	CI	6.66
1a				135	-	65	80	1.5	105.5	75	182	CI	-
75 1	4750	1280	1920	160	135	30	75	1.0	120.0	85	206	CI	10.48
1a				160	-	75	95	1.0	120.0	85	206	CI	-
90 1	3750	2400	3600	200	160	40	90	1.5	139.5	100	241	CI	17.89
1a				200	180	90	115	1.5	139.5	100	241	CI	-

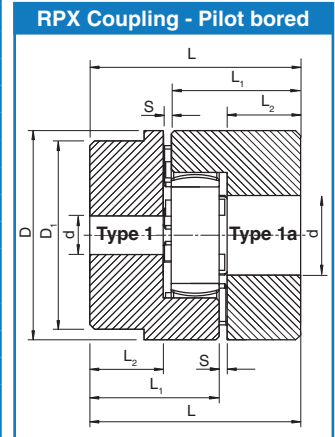

RPX Coupling Data - Taper bored

TYPE	Max Speed rev/min	Rated Torque		Bush Size	Max Bore	D	D ₁	S	L ₁	L ₂	L	Material	Weight kg/hub
		92 shore Nm	98 shore Nm										
24 F	14000	35	60	1008	25	56	-	1.0	39.0	23	63	CI	0.31
H				1008	25	56	-	1.0	39.0	23	63	CI	0.31
28 F	11800	95	160	1108	28	65	-	1.5	40.5	23	65	CI	0.46
H				1108	28	65	-	1.5	40.5	23	65	CI	0.46
38 F	9500	190	325	1108	28	80	78	1.0	44.0	23	68	CI	0.79
H				1108	28	80	78	1.0	44.0	23	68	CI	0.79
42 F	8000	265	450	1610	42	95	94	1.0	49.0	26	76	CI	1.10
H				1610	42	95	94	1.0	49.0	26	76	CI	1.10
48 F	7100	310	525	1615	42	105	104	1.5	63.5	39	104	CI	2.07
H				1615	42	105	104	1.5	63.5	39	104	CI	2.07
55 F	6300	410	685	2012	50	120	118	2.0	59.0	33	94	CI	2.22
H				2012	50	120	118	2.0	59.0	33	94	CI	2.22
65 F	5600	625	940	2012	50	135	133	1.5	63.5	33	98	CI	3.14
H				2517	65	135	133	1.5	75.5	45	122	CI	4.03
75 F	4750	1280	1920	2517	65	160	135	1.0	81.0	46	128	CI	4.69
H				3020	75	160	135	1.0	87.0	52	140	CI	4.99
90 F	3750	2400	3600	3020	75	200	160	1.5	91.5	52	145	CI	7.74
H				3525	100	200	160	1.5	103.5	64	169	CI	8.74

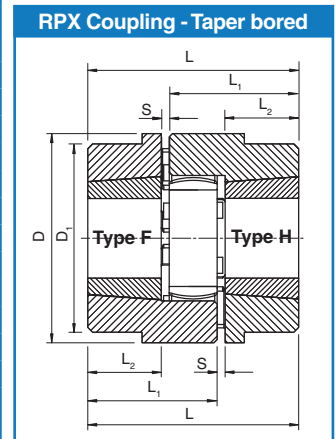

RPX Elements are manufactured from polyurethane and are available in Shore 92 (yellow) and Shore 98 (red) hardness

Material: Al = Aluminium CI = GG25 Cast Iron

Jaw Couplings

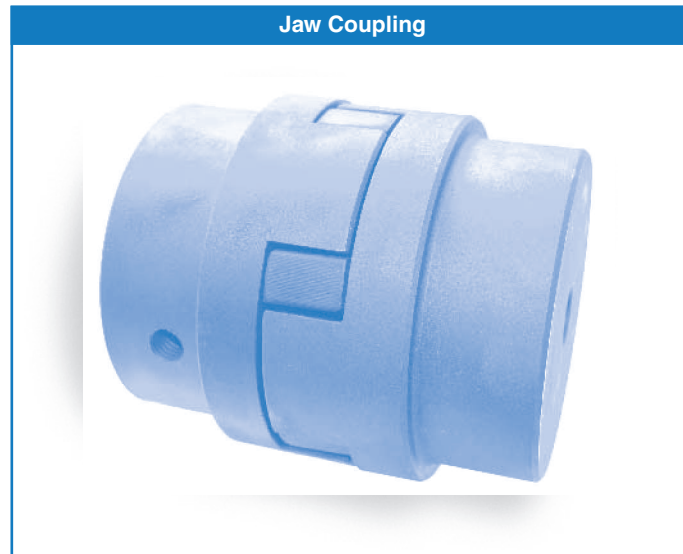

Jaw Coupling Data

Coupling Size	Nominal Torque Nm	Maximum Speed rev/min	Pilot Bore A	Maximum Bore A	Overall Diameter B	Assembled Length L	Hub Width C	Hub Diameter D	Set Screw Position F	Set Screw Size	Complete Weight kg
035	0.50	31000	4.8	8	16.0	20	7	16.0	3.0	M3	0.06
050	3.51	18000	6	14	27.5	44	16	27.5	6.5	M6	0.10
070	5.77	14000	9	19	35.0	51	19	35.0	9.5	M6	0.25
075	11.9	11000	9	24	44.5	54	21	44.5	8.0	M6	0.45
090	19.2	9000	9	24	54.0	54	21	54.0	8.7	M6	0.55
095	25.8	9000	9	28	54.0	64	25	54.0	11.5	M8	0.65
100	55.4	7000	12	35	65.0	89	35	65.0	12.5	M8	1.60
110	105	5000	15	42	84.0	108	43	84.0	20.5	M10	3.00
150	150	4000	15	48	96.0	115	45	96.0	22.5	M10	4.90
190	200	3600	19	55	115.0	133	54	102.0	22.5	M12	7.00
225	280	3600	19	60	127.0	153	64	108.0	25.5	M12	9.00

Angular misalignment capacity up to 1°
Parallel misalignment capacity up to 0.38mm

Weight is for a complete coupling with a pilot bore
Nitrile insert temperature range -40 °C to 100 °C

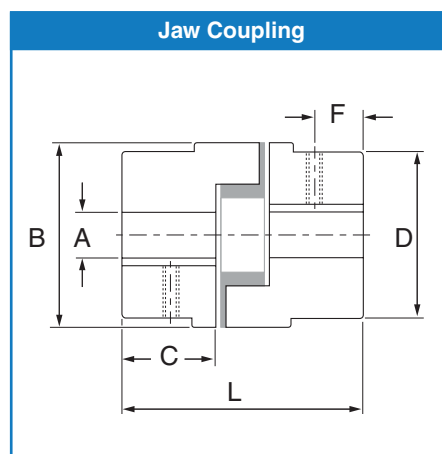

Chain Couplings

Chain Coupling Data

Coupling Size	Chain Size	Bore		Casing O.D. A	Casing Width B	Assembled Width C	Hub Length D	Hub Diameter E	Bolt Centres F	Torque Ratings Nm	Complete Weight kg
		Min	Max								
3012	35-2	12	15	70	62	65	28	25	57	150	0.5
4012	40-2	12	20	78	72	78	36	31	61	210	1.0
4014	40-2	12	25	85	75	80	36	43	72	300	1.4
4016	40-2	14	30	92	75	80	36	50	77	380	1.8
5014	50-2	14	35	101	84	100	45	53	82	550	2.5
5016	50-2	16	40	111	85	100	45	60	92	725	3.2
5018	50-2	16	45	123	85	100	45	70	106	925	4.0
6018	60-2	20	55	144	106	122	54	85	122	1750	7.2
6020	60-2	20	70	160	108	123	54	98	132	2050	9.5
6022	60-2	25	75	168	116	123	54	110	145	2400	11.3
8018	80-2	30	75	190	128	140	67	110	160	3800	14.7
8020	80-2	30	85	211	138	144	67	120	184	4700	18.2
8022	80-2	35	95	226	138	155	67	140	196	5500	23.3
10020	100-2	40	110	280	152	176	91	160	250	8700	36.0
12018	120-2	40	120	305	180	196	119	170	280	13250	49.0
12022	120-2	40	150	355	180	220	119	210	335	17800	77.0

Chain Coupling Selection

In general, the torque capacity of the coupling exceeds the normal torque transmitted by the largest shaft size that the coupling can accommodate.

Therefore, select the smallest coupling which accommodates both shaft diameters.

Where there is reverse operation, shock loads, or any other severe operating condition, it is recommended that the next coupling size up is selected.

Operation

In order to ensure that the maximum service life of the coupling is achieved, the cover together with the supplied 'O' rings should always be used. This is even more important when the drive is operating at high speeds or in a moist environment. The space between the cover and chain, should be filled with a soft to medium consistency grease.

